

Spool valve

Flange construction

- ◆ roller operated
- ◆ 4/2-way with spring reset
- ◆ $Q_{max} = 100$ l/min
- ◆ $p_{max} = 350$ bar

NG10
ISO 4401-05

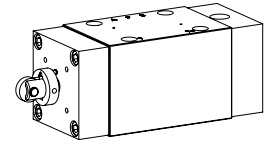

DESCRIPTION

Direct operated valve, roller operated with 4 connections in 5 chamber design. Without actuation, the spool is switched back to the offset position. Precise spool fit, low leakage, long service life time. Spool made from hardened steel, body from high quality hydraulic cast steel.

APPLICATION

Spool valves are mainly used for controlling direction of movement and stopping of hydraulic cylinders and motors. The direction of movement is determined by the position of the spool and its symbol. Manually or mechanically operated valves are particularly suitable for use in installations where no electric current is available or for applications in explosion hazard areas.

TYPE CODE

International standard interface ISO	A T 4 <input type="checkbox"/> - <input type="checkbox"/> # <input type="checkbox"/>	
Roller with spring reset		
Number of control ports		
Designation of symbols acc. to table	Operation a-side <input type="checkbox"/> Operation b-side <input type="checkbox"/>	
Sealing material	NBR <input type="checkbox"/> FKM (Viton) <input type="checkbox"/> D1	
Design index (subject to change)	1.5-55	

GENERAL SPECIFICATIONS

Designation	4/2-spool valve
Construction	Direct operated
Mounting	Flange construction
Nominal size	NG10 according to ISO 4401-05
Actuation	Roller operated
Ambient temperature	-25...+70 °C (NBR) -20...+70 °C (FKM)
Weight	3,5 kg

HYDRAULIC SPECIFICATIONS

Working pressure	$p_{max} = 350$ bar
Tank pressure	$p_{Tmax} = 100$ bar
Maximum volume flow	$Q_{max} = 100$ l/min, see characteristics
Leakage oil	See characteristics
Fluid	Mineral oil, other fluid on request
Viscosity range	12 mm ² /s...320 mm ² /s
Temperature range fluid	-25...+70 °C
Contamination efficiency	Class 20 / 18 / 14
Filtration	Required filtration grade $\beta_{10...16} \geq 75$, see data sheet 1.0-50

ACTUATION

Actuation	Roller
Actuation stroke	$s = 3,8$ mm
Actuation force	$F_b = 100 - 180$ N

SYMBOL
Overview valves

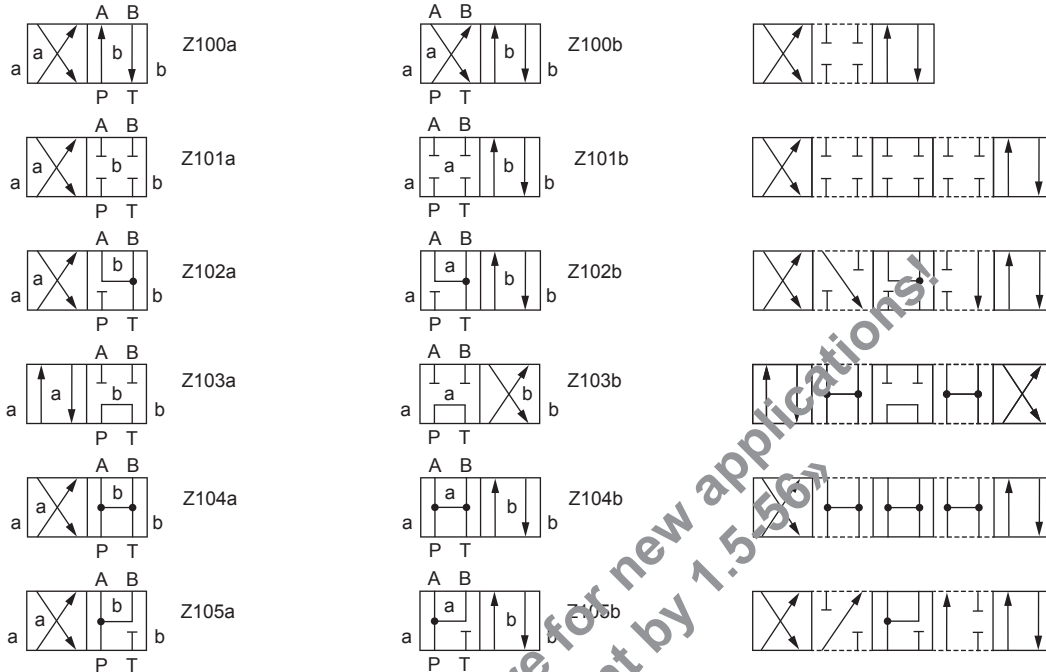
Overview spool types

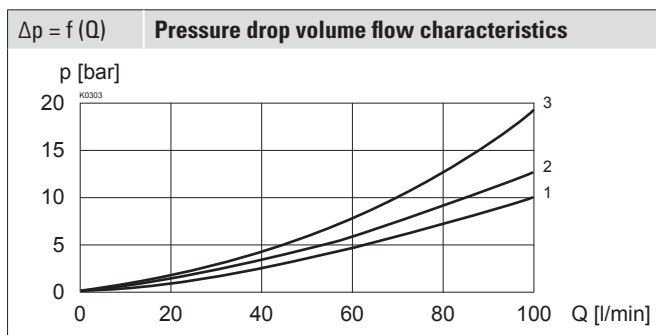
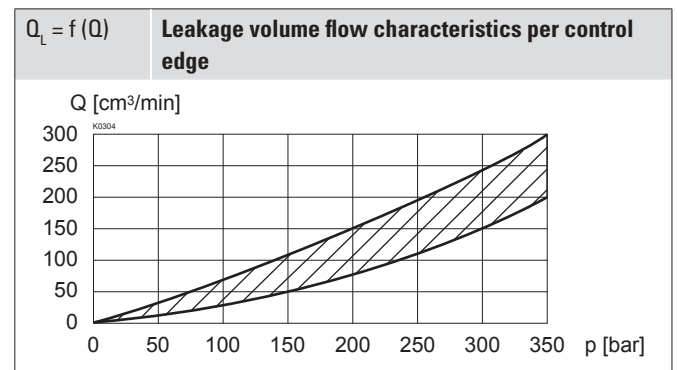
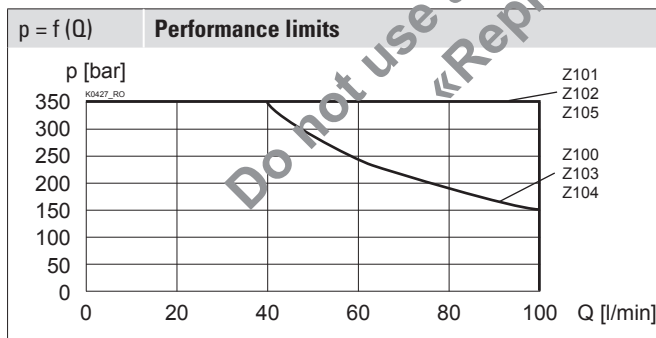
PERFORMANCE SPECIFICATIONS

 Oil viscosity $\nu = 30 \text{ mm}^2/\text{s}$

Symbol	Volume flow direction				
	P - A	P - B	P - T	A - T	B - T
Z100	2	2	-	2	2
Z101	2	2	-	2	2
Z102	2	2	-	1	1
Z103	2	2	3	2	2
Z104	1	1	-	1	1
Z105	1	1	-	2	2

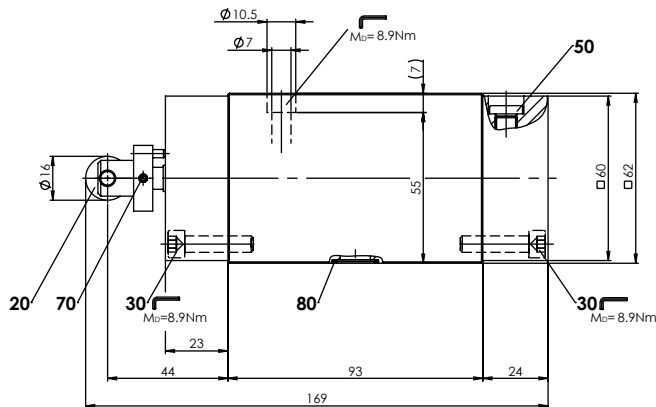
DIMENSIONS



Width of roller = 4,8 mm

HYDRAULIC CONNECTION

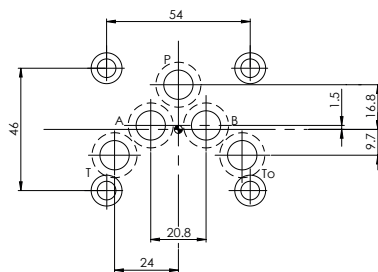

STANDARDS

Mounting interface	ISO 4401-05
Contamination efficiency	ISO 4406

INSTALLATION NOTES

Mounting type	Flange mounting 4 fixing holes for socket head screws M6 x 65
Mounting position	Any, preferably horizontal
Tightening torque	$M_D = 8,9\text{ Nm}$ (screw quality 8.8, zinc coated) Fixing screws

Note!



The length of the fixing screw depends on the base material of the connection element.

PARTS LIST

Position	Article	Description
20	253.4100	Mechanical control head ATII
30	246.3126	Socket head screw M6 x 25 DIN 912
50	238.0201	Socket head screw M8 x 1 DIN 908
70	221.2272	Spring tension split pin $\phi 3 \times 16$ DIN 1481
80	160.2140	O-ring ID 14,00 x 1,78 (NBR)

ACCESSORIES

Fixing screws	Data sheet 1.0-60
Threaded subplates	Data sheet 2.9-40
Multi-station subplates	Data sheet 2.9-70
Horizontal mounting blocks	Data sheet 2.9-110
Technical explanations	Data sheet 1.0-100
Hydraulic fluids	Data sheet 1.0-50
Filtration	Data sheet 1.0-50

SEALING MATERIAL

NBR or FKM (Viton) as standard, choice in the type code

SURFACE TREATMENT

- ◆ The valve body is painted with a two component paint
- ◆ The roller housing, the screws and the cover are zinc coated